

One-Point Perspective (street scene)

Below are basic steps for creating a street scene in one-point perspective. They will help to get you started. Expand on this approach by adding different details like windows, roads, benches, lights, people, clouds, and cars. You can use the back of this sheet to draw your scene.

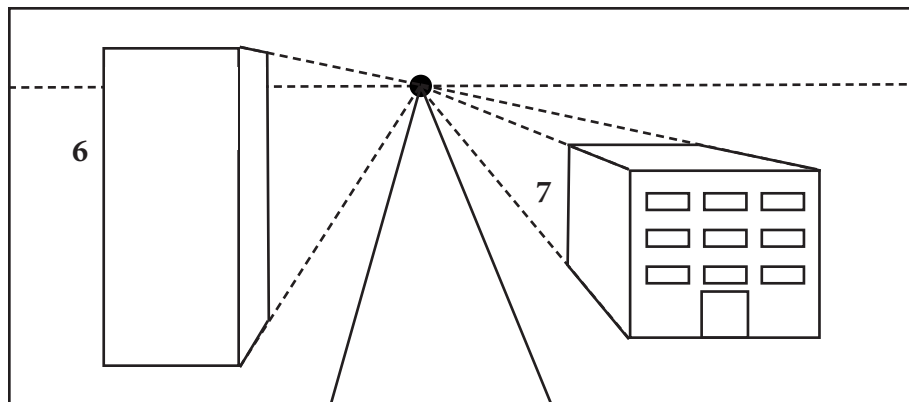
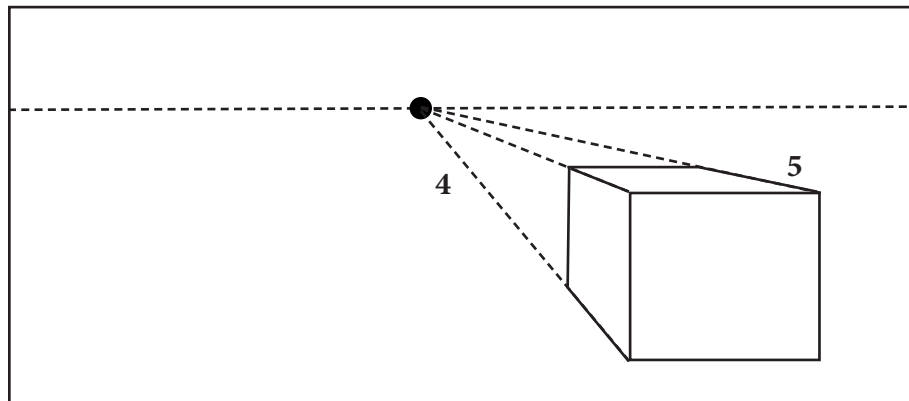
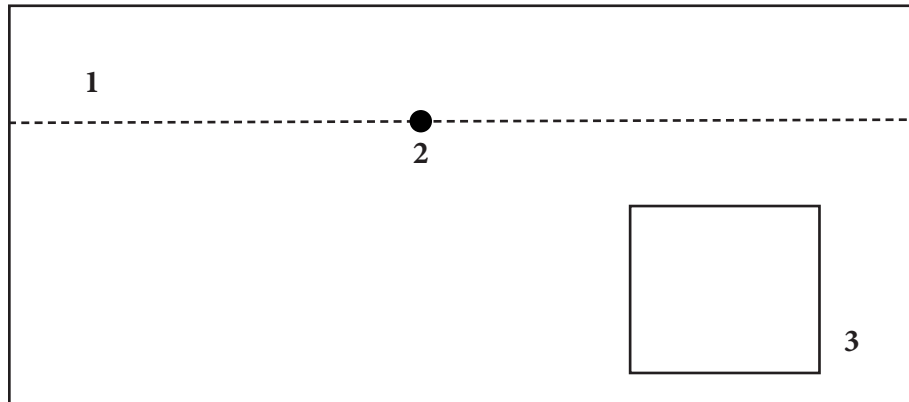

INSTRUCTIONS

1. Draw the horizon line (dotted line).
2. Mark the vanishing point (small circle).
3. Draw a square or rectangle (1st building)
4. Draw lines from the corners of the square to the vanishing point.
5. Draw vertical and horizontal lines to enclose the building.
6. Add more details like other buildings, windows, roads, and sidewalks.
7. Erase the guiding lines converging toward the vanishing points.

MATERIALS

Paper
Pencil and or pen
Eraser
Ruler

TIPS

Begin by drawing lines lightly with your pencil and finalize by drawing darker lines with pen.

Use a reference such as your own street or a favorite part of the city,

Let mistakes happen. Have fun!

**Drawing from
Observation
Home Activity**
Contemporary Art
Museum St. Louis

December 2020

