

Two-Point Perspective (street scene)

Below are basic steps for creating a street scene in two-point perspective. They will help to get you started. Expand on this approach by adding different details like windows, roads, benches, lights, people, clouds, and cars. You can use the back of this sheet to draw your scene.

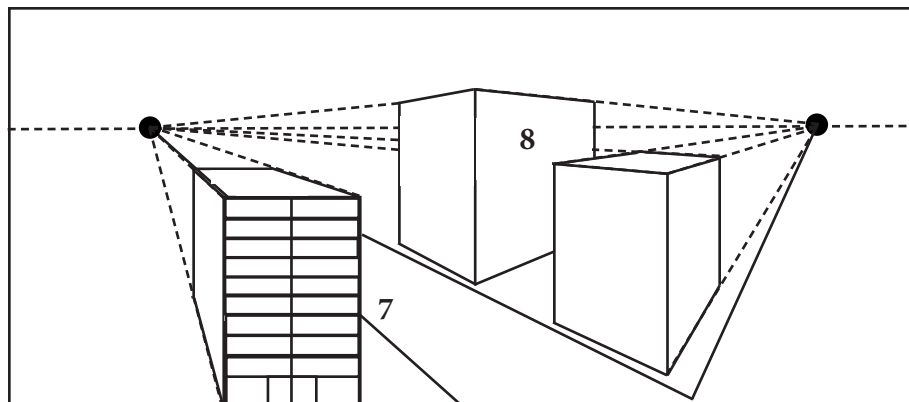
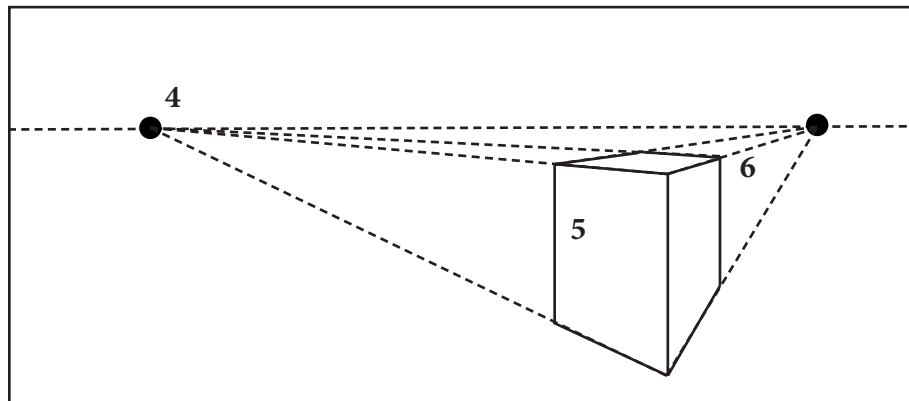
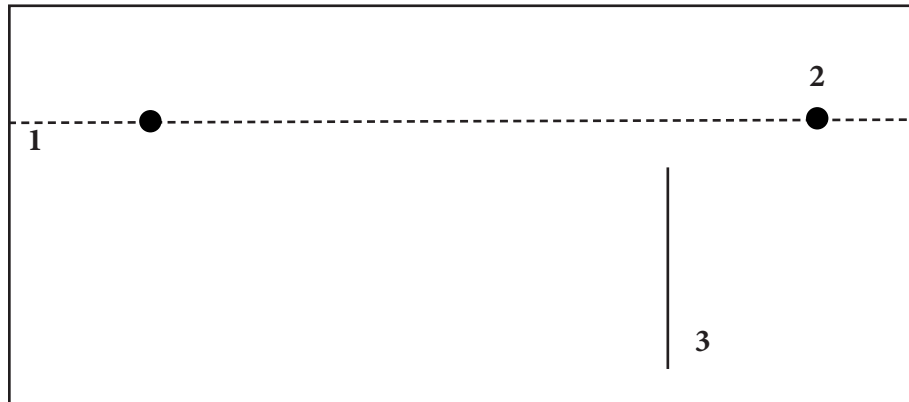

INSTRUCTIONS

1. Draw the horizon line (dotted line).
2. Mark two vanishing points (circles).
3. Draw a vertical line. (front edge of 1st building)
4. Draw lines from the top and bottom of your line to both vanishing points.
5. Draw vertical lines for the other edges of the building.
6. Draw lines to connect the top corners opposite of the vanishing points.
7. Add more details like other buildings, windows, roads, and sidewalks.
8. Erase the guiding lines converging toward the vanishing points (dotted lines).

MATERIALS

Paper
Pencil and or pen
Eraser
Ruler

TIPS

The ruler is your best friend.
Use it for every line you make.

Begin by drawing lines lightly with your pencil and finalize by drawing darker lines with pen.

Use a reference such as your own street or a favorite part of the city,

Let mistakes happen. Have fun!

**Drawing from
Observation
Home Activity**
Contemporary Art
Museum St. Louis

December 2020

